



The “MINI RIG” range offers the directional driller a high quality swivel at a competitive price. Using all our big swivel expertise we have engineered a range of compact and durable swivels for the cost conscious operator.

Features -

- ❖ Patented sealing system keeps bentonite out but allows power greasing.
- ❖ Shaft & clevis made from single steel billet - gives maximum strength and durability.
- ❖ Clevis to clevis design.
- ❖ Sizes – US Tons 10, 15, 20, 30.
- ❖ Easy access side grease nipple.



MiniRig™ HDD Swivels

technical specifications

we reserve the right to amend the specifications without notice. E&OE

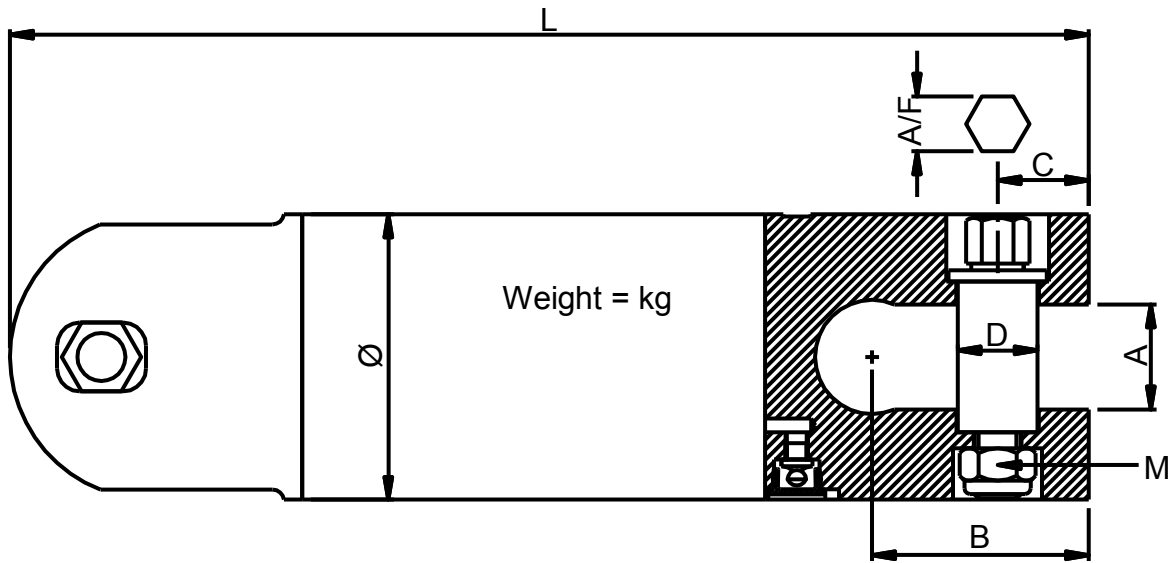
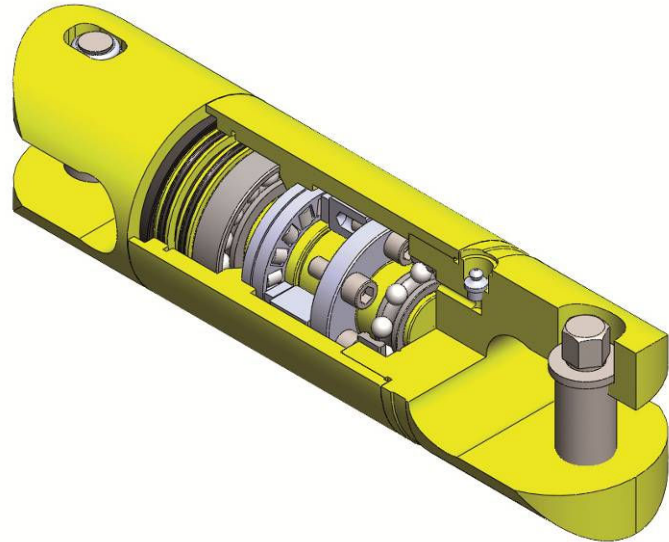

Swivel	Part No.	SWL lb	SWL kg	L	Ø	A	B	C	D	A/F	M	kg
10 US Ton	11-010	20,000	9000	345	80	38	67	25	25.4	17	m20	9
15 US Ton	11-015	30,000	13600	442	108	44	99	37.5	29	20	m16	22
20 US Ton	11-020	40,000	18100	473	125	46	95	40	35	24	m20	32
30 US Ton	11-030	60,000	27200	493	138	46	101	43	35	24	m24	41

All dimensions in mm, weights and dimensions subject to change without notice.

Jun 2015

brewisengineering.co.uk

Brewis Engineering Limited Handlemaker Road
 Marston Trading Estate Frome Somerset BA11 4RW
Tel: +44 (0)1373 468864 Fax: +44 (0)1373 468865
sales@brewisengineering.co.uk



© Brewis Engineering Limited 2010