

SUPERIOR QUALITY HDD EQUIPMENT

Serving the Horizontal Directional
Drilling industry

FULL LINE CATALOG



SITETEC

HDD EQUIPMENT

WE KNOW THE DRILL

Dedication mixed with
30 years of experience.



ONLY THE BEST IS GOOD ENOUGH

Your satisfaction

As a company, our history goes back more than 15 years. In 2001 the company was founded with the belief, "Only the best is good enough" which remains the guiding principle of our company today.

**Quality Service is Built into Every SiteTec Product
HDD equipment built for professionals**

We believe our products must live up to your highest expectations. And our service must live up to the quality of our products. We are satisfied only when you are!



BUILT TO LAST

Designed using our extensive experience we only supply top end units, built for highest performance and durability.

DETAILS ARE NOT THE DETAILS, they make the design.

Specifically the smallest details such as: steel cable ducts to protect wiring on the units, double outlet on the recyclers, folded edges on the checker plated walkway preventing fall back of debris into the tanks, use of thick piping for longest lifespan, Stainless steel control and remote control boxes, use of many Victaulic connectors and butterfly valves for easiest and quickest maintenance, Sandblasted and painted in 2-component industrial RAL (colour of choice), also inside of the tanks! and Curved tank bottoms for optimal flow and to prevent settling of debris, All underline the thoughtful construction.

EVERYTHING IN STOCK

We have a comprehensive range of parts available.

Our stock not only includes largest spare inventory but also a full line of Tools & Accessories!

Due to standardisation in many components (like pumps etc) parts are exchangeable between many units, which optimizes spare parts use and eases searching for the right parts and so saves costs.

TOTAL PACKAGE SOLUTIONS

we have your needs covered

EXPERT ADVICE

Only with the right selected mud system the optimum is achieved from the drilling rig! Using our 30 year experience we are able to assist and recommend customers from offer until first commissioning on site. The weakest link in the whole process determines the success.

Units are designed for quickest rig-up and rig-down time and easy and efficient transport (ao. foldable walkways, no crane required for set-up and special airbladders that do not need fixation before transport). Therefore the systems offer the smallest possible footprint and the logistics have been taken into account from the first design.

HASSLE FREE

Our service does not stop at just providing mud systems. We are there for our clients to fully support them up to and including transport. We thus offer a complete range of solutions all under one roof.

EXPERT INCLUDED

When we say "Expert Included", we mean it! Our team is knowledgeable, personable and eager to be of full support.

AT YOUR SERVICE

Always available



Full service support in -house and on-site.



CUSTOM BUILD

EACH CUSTOMER HAS THEIR OWN IDEAS AND WISHES

Naturally SiteTec is eager to listen and learn from its customers. To a great extent the ultimate success strongly depends on that.

Although as much as possible is standardized and based on tested concepts, customer-specific build (or modification) of an installation is more the rule than the exception. Therefore SiteTec sees special construction as one of the biggest challenges and has made it the house specialty.



RENTAL

SiteTec offers the largest and most complete rental fleet of HDD mud equipment

With a fleet of approx. 40 units varying from Mix-, pump, recycling systems and accessories like piperollers and hoses we are ready for your requirements. Rental units are the ideal solution to cover down time on your own equipment, lack of equipment or even try-out of new system technology.



USED EQUIPMENT

SiteTec has access to a large market of used equipment.

We are interested in any kind of HDD system, no matter the brand! This has enabled us to offer a wide range of used equipment which is unique in the market.

We challenge you to ask for our sharpest offer.



PROUD TO SERVE YOU



We are dedicated to superior workmanship and adhere strictly to our budget, schedule and service commitments.

WE BELIEVE QUALITY, INTEGRITY AND HONESTY SET SITETEC APART FROM OTHER BUILDERS

We understand the importance of each and every project, from the smallest to the largest. We give all clients the personalized attention that every project requires.

SiteTec has achieved its position by knowing that our equipment owners are a breed-apart. We understand they are the kind of hard working, determined people that demand the same kind of performance from their equipment. This is what we keep in mind from concept through commissioning of our equipment.

SiteTec strives to stay on the leading edge of technology and innovation in the industry.





SUPERIOR QUALITY EQUIPMENT

Serving the Horizontal Directional
Drilling industry

- 10** Mix systems
- 12** Pump systems
- 14** Mud plants (Mixing-and High Pressure Pumping system)
- 16** Recycling systems
- 18** Recycling- and Mix systems
- 20** Storage systems
- 22** Slurry / Vacuum systems &
Transfer / Booster pumps
- 24** Parts
- 26** Additional equipment
- 28** Tools & accessoires



“A good start of fluid preparation is half the battle”

MIX SYSTEMS

Flow range up to 2500 ltr/min. These high shear venturi mixing systems with UV stabilized PE- or steel tank & in-tank nozzle system get the job done!



The centrifugal mixing pump (with Hard Iron Mechanical Seal) is driven by a Diesel, Petrol or Electric motor.

Main features:

- ✓ Smallest footprint offering highly efficient logistics
- ✓ Very easy operation and maintenance
- ✓ Agitation by means of venturi, in-tank nozzle system and submersible agitator (some models)
- ✓ Quickest rig-up and rig down times
- ✓ Standard equipped with waterfilter and (depending on model size) an intake connection for recycled mud.
- ✓ Thick steel piping (no hoses) with use of many victaulics
- ✓ Curved tank bottoms for optimal flow and prevent settling of debris

CE certification of conformity as well a full manual are included, and all system are sandblasted and painted in 2-component RAL colour of choice (non-metallic) including inside of the tanks.





“The pump system is the beating heart of the entire HDD system”

PUMP SYSTEMS

Flow range up to 2500 ltr/min, pressure up to 300 bar.
These self-contained High Pressure pumps can be equipped with different brands of pumps and engines.



P2500D



P250DH



P500D

ENGINE BRANDS

- Hatz
- Kubota
- Cummins
- Caterpillar
- John Deere
- And many more



P1000DH

PUMP BRANDS

- FMC
- Kerr
- Gardner Denver
- SiteTec ST 250
- Schäfer & Urbach
- Ellis Williams
- And many more

SiteTec offers pump systems mounted in open skids, standard ISO containers or fully sound attenuated skids.

Main features:

- ✓ Extreme duty, extremely reliable
- ✓ Easy to operate and maintain
- ✓ Mechanical drive is best in case of use mud motors!
- ✓ Standard pulsation dampener
- ✓ Super silent: designed to run under full load with closed doors
- ✓ Mechanical and several electronic safety features

Most units feature a well proven mechanical drive, diesel or electric. Other models Hydraulic. Mechanical drive gives best stable flow and best fuel efficiency.



P1500D

CE certification of conformity as well as full manual is included, and system is sandblasted and painted in 2-component RAL colour of choice (non-metallic).



“Minimize logistics, Optimize your efficiency !”

MUD PLANTS

Flow range up to 1000 ltr/min. These self-contained Mixing- & High Pressure Pump systems feature a high shear venturi mixing system and high pressure pump, offering the best of both worlds in one compact machine.



MP1000DHC



MP180DH



MP182H



MP202DH



MP502DH

All Mix- & high pressure pump systems are diesel-hydraulic driven.

Main features:

- ✓ Mixing and pumping in one compact unit
- ✓ Saving on logistics specifically at small projects with quickest rig-up and rig down times
- ✓ Agitation by means of venturi, in-tank nozzle system and submersible agitator (some models)
- ✓ Super silent: designed to run under full load with closed doors
- ✓ Mechanical and several electronic safety features
- ✓ Standard equipped with waterfilter and (depending on model size) an intake connection for recycled mud.
- ✓ Thick steel piping (no hoses) with use of many victaulics
- ✓ Curved tank bottoms for optimal flow and prevent settling of debris
- ✓ Optional crane (some models)
- ✓ Easy to operate and maintain enables handling of bigbags

CE certification of conformity as well as full manual is included, and system is sandblasted and painted in 2-component RAL colour of choice (non-metallic) including inside of the tanks.



MP750DH



“Save the environment whilst minimizing mud costs and optimizing total process control”

RECYCLING SYSTEMS

Flow Range up to 2500 ltr/min. These recycling systems are based on the latest design of Recycling technology for HDD operations. Features like the foldable walkways and special airbladders instead of old-fashioned springs optimize the logistics for the systems.



R2500E

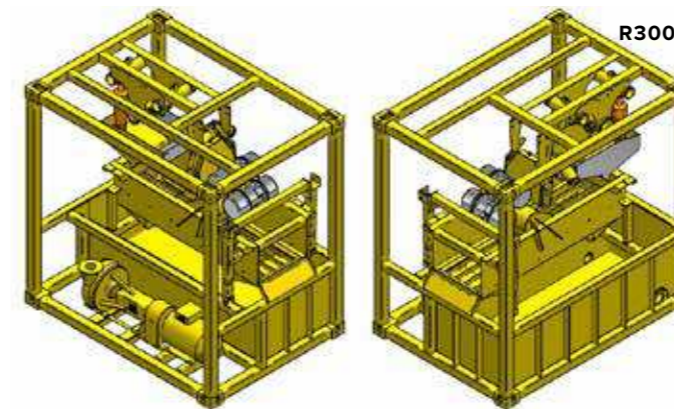

R300E



R500E



R1000E



R1000E

Logistics:

- ✓ Plug and Play unit. Upon arrival only 2-3 hoses and the generator need to be connected.
- ✓ No heavy lifts with frame parts, hoses, piping or such is required. Only opening of the foldable walkway and safety rails setup.
- ✓ No parts like the shakers have to be secured before transport which save even more time.

Capacity:

2500 ltr/min. Is actually 2500 ltr/min! 20% sand inlet, less than 1% out @ 60 sec viscosity 1.2 gr/cc spec. gravity

Operation:

The shakers are working parallel which offers the big advantage that one can stop one shaker for screen change or such whilst keep recycling over the remaining shakers. So one shaker cannot cause a complete standstill of the entire



R1500E

CE certification of conformity as well as full manual is included, and system is sandblasted and painted in 2-component RAL colour of choice (non-metallic) including inside of the tanks.



“Offering the very best of both worlds”

RECYCLING- & MIX SYSTEMS

With flow range up to 2500 ltr/min these combined units offer both Mixing and Recycling in one machine, offering the best of both worlds in one compact machine.



In case of sufficient returns or during the pilot, there is no need for a high mixing capacity. So this compact unit is able to clean and recondition your fluid.

Main features:

- ✓ Recycling and Mixing in one compact unit with the smallest footprint
- ✓ Saving on logistics
- ✓ Easy to operate and maintain
- ✓ Quickest rig-up and rig down times
- ✓ Thick steel piping (no hoses) with use of many victaulics
- ✓ Curved tank bottoms for optimal flow and prevent settling of debris

CE certification of conformity as well as full manual is included, and system is sandblasted and painted in 2-component RAL colour of choice (non-metallic) including inside of the tanks.





“So much more than a plain tank”

STORAGE SYSTEMS

Flow range up to 4000 ltr/min.



ST4000E

These systems all feature a curved tank bottom for optimal agitation of the mud, which is done by a special in-tank nozzle system offering optimal mud storage (strong circulation in combination with curved tank preventing settling of debris).

The Storage units are standard equipped with:

- ✓ Remote control with 50 mtr cable
- ✓ Outlet is automatic controlled
- ✓ Optional Charge pump filter

The centrifugal pumps are electric driven. All Storage systems require a generator as they are all equipped with electrical motors.

CE certification of conformity as well as full manual is included, and system is sandblasted and painted in 2-component RAL colour of choice (non-metallic) including inside of the tanks.



C10 STORAGE CONTAINER
+ SHALE SHAKER



R2500E + ST1500E



R2500E + ST2000E



ST2500E



SLURRY/VACUUM & TRANSFER/BOOSTER PUMPS



TP1000D

Submersible Pitpumps:

Electric driven, extremely compact
With best price- quality level.

Slurry/vacuum systems:

These self-priming pumps offer completely automatic priming and Unique performance in effluent disposal and slurry handling.

Transfer/Booster systems:

The Transfer/Booster pumps are made to feed the high pressure pumps and for long distance pumping.

CE certification of conformity as well as full manual is included, and system is sandblasted and painted in 2-component RAL colour of choice (non-metallic).



PS4D + PS6D



PM4E + PM6E



PS4E



PS6E



PM8D



PARTS

SiteTec offers a full range of parts for the HDD market. Need a special part? WE WILL FIND IT FOR YOU



- ✓ Parts for mud systems (Mix-, Pump- Recycling systems and many more)
- ✓ Parts for other HDD related equipment

SiteTec keeps up with the latest technology in wear parts, tools and accessories. And can build customized parts for your applications. Or can rebuild your pump with original or modified parts, up to factory standard with full warranty.

SiteTec is stocking distributor for:

- SiteTec ST250
- Kerr pumps
- FMC
- Schäfer & Urbach
- Weatherford
- Ellis Williams
- Gardner Denver
- Gaso
- Gorman Rupp
- Selwood Seltorque
- Johnson
- Essick
- MCM, Mission, Mattco, Magnum, etc.
- Gearench Tongs
- Rotaflow Swivels

SiteTec keeps this extensive range in stock for quick delivery to ensure minimum down time to our customers.





“To complete our service we offer a full line of additional equipment to our customers”

ADDITIONAL EQUIPMENT



Pipe rollers for a pipe diameter up to 1600 mm and Roller cradles

- ✓ STR 500
- ✓ STR 800
- ✓ STR 1200
- ✓ STR 1600
- ✓ Roller cradles

- ✓ Generators sets in a range from 50 kVA up to 1000 kVA
- ✓ Vacuum sets
- ✓ Welding systems in a range from 32 mm up to 1500 mm
- ✓ Auger boring systems in a range of 90 up to 1200 mm



CRANE BASE



C-CRADLES



GENERATORS



VACUUM SET



WELDING SYSTEMS



ROLLER CRADLES



(GUIDED) AUGER BORING SYSTEMS



CUSTOM BUILD



TOOLS & ACCESSORIES

Swivels, tong dies, Breakout tongs, bentonite, Tungsten Nozzles, Pulling heads, Mud Measuring sets, Reamers, Fly Cutters..... YOU NAME IT WE GOT IT



- ✓ Drilling tools like drill heads and reamers.
- ✓ Mud swivels and pulling swivels.
- ✓ Drilling fluids and mud measure equipment.
- ✓ Various wear parts like tong dies and pick points.

SiteTec keeps this extensive range in stock for quick delivery throughout Europe and beyond. SiteTec keeps up with the latest technology in wear parts. SiteTec can build customized parts for your applications. SiteTec can supply tooling and wear parts for most brands of HDD machines.

SiteTec is official distributor for oa.:

- Gearench Tongs
- Baroid
- Rotaflow Swivels
- And many more



INTERNATIONAL SUPPORT

To be of very best possible service and support to our customers SiteTec has an extensive international dealer network. Benefits of a local contact is quickest response, no language barriers, local engineers available and parts within a hand reach.

We are ready to be of service!



DEDICATED
TO superior
workmanship



SITETEC
HDD EQUIPMENT

WWW.SITETEC.NL

Office address
Molenvliet 28
3961 MW Wijk bij Duurstede
The Netherlands

Mail address
P.O.Box 138
3960 BC Wijk bij Duurstede
The Netherlands

Contact
(T) +31 (0)343 595 400
(F) +31 (0)343 595 404
(E) info@sitetec.nl